

Firesafe application type **Acoustic and fire**Construction type **Internal Partition Walls**

ROCKWOOL®

Acoustic Slab

An easy-to-fit, semi-rigid slab for acoustic metal partitions

Rockwool Acoustic Slab is a high quality resin bonded semi-rigid slab, designed to combine optimum acoustic and fire performance with easy fitting into metal partitions.



Advantages

- Excellent acoustic absorption
- Simple and fast installation
- Optimum dimensions to suit metal stud partitions
- A1 Fire classification
- No sagging or slumping
- New slimmer 25 mm thickness



Complies with
Approved Document E 2003 edition

Meeting Approved Document E (ADE)

The Approved Document E (2003 edition) introduces, for the first time, performance criteria for internal walls. This is based on laboratory rating (R_w) for which a minimum value for airborne sound insulation of 40 dB is required. ADE Section 5 internal wall type B gives examples of metal stud construction that should achieve this value.

New 25 mm thickness using standard 12.5 mm plasterboard

The new slimmer 25 mm thickness Acoustic Slab is available to comply with ADE-part E2.

This has been laboratory tested using standard 12.5 mm plasterboard (8 Kg/m²) in a 50 mm metal stud and achieved R_w 41 dB (BRE L03 185).

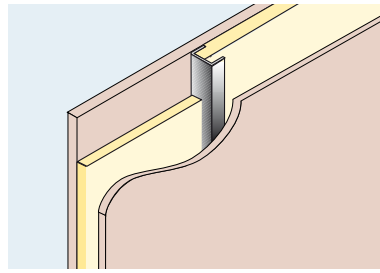

Metal stud wall construction

ADE Section 5, internal wall type B

R_w 40 dB

- Minimum 48 mm lightweight metal studs @ 600 mm centres.
- Rockwool Acoustic Slab (min) 25 mm.
- Single layer plasterboard (10 Kg/m²) both sides.

Exceeding Approved Document E

Superior solutions for enhanced performance

These solutions have been laboratory tested to give a superior acoustic performance where a high level of airborne sound insulation is required over and above the minimum regulations of Approved Document E.

Enhanced performance using 50 mm studs

Where space is at a premium, Rockwool provides a 47 mm thick Acoustic Slab to fill between 50 mm wide metal studs.

Weighted sound reduction index R_w 43 dB

Fire resistance 30 minutes

Studs 50 mm width @ 600 mm centres

Facings One layer of 12.5 mm plasterboard (10 Kg/m²) both sides

Insulation 47 mm Acoustic Slab

Report No BTC 10192A

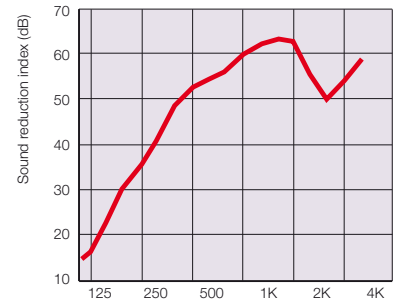
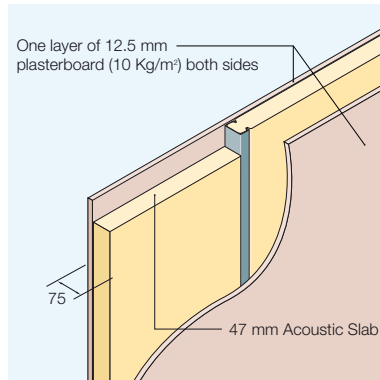

Weighted sound reduction index: R_w 43 dB
Test report No. BTC 10192A

Typical office, conference or board room partitions

(a)

Weighted sound reduction index R_w 54 dB

Fire resistance 30 minutes

Studs 70 mm width @ 600 mm centres

Facings One layer of 15 mm plasterboard (13 Kg/m²) one side.

Other side one layer of 15 mm plasterboard

(13 Kg/m²) fixed to resilient bar.

Insulation 67 mm Acoustic Slab

Report No BTC 10189A

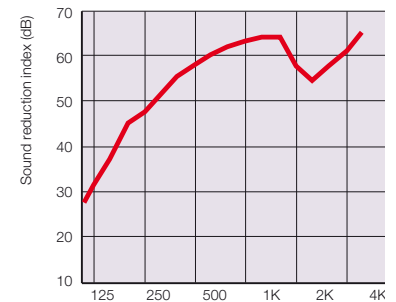
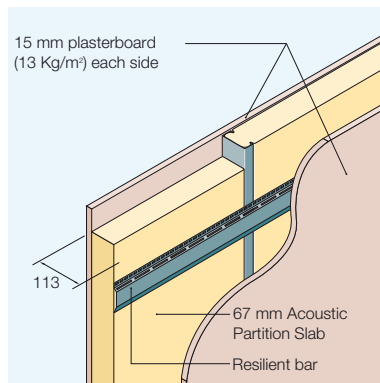

Weighted sound reduction index: R_w 54 dB
Test report No. BTC 10189A

(b)

Weighted sound reduction index R_w 55 dB

Fire resistance 60 minutes

Studs 70 mm width @ 600 mm centres

Facings Two layers of 12.5 mm plasterboard

(16 Kg/m²) both sides

Insulation 67 mm Acoustic Slab

Report No BTC 10191A

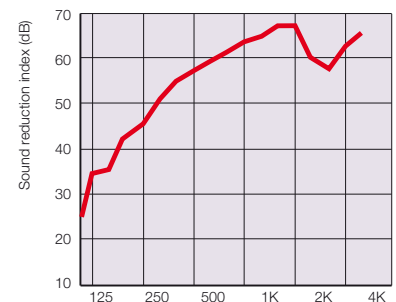
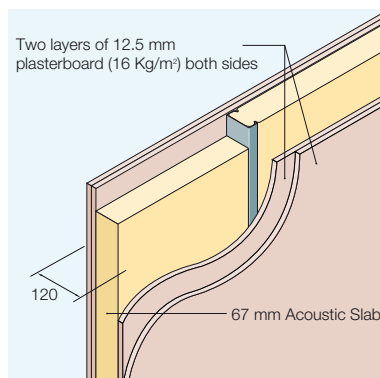

Weighted sound reduction index: R_w 55 dB
Test report No. BTC 10191A

Metal Stud Partition structure

	Specification	Nominal thickness (mm)	Weighted sound reduction index (R _w dB)	Fire Resistance (minutes)
70 mm stud. No insulation	Studs 70 mm width @ 600 mm centres. Facings One layer 12.5 mm plasterboard (10 Kg/m ²) both sides No insulation	95	36	30
70 mm stud with 67 mm Acoustic Slab	As above with 67 mm Acoustic Slab Report No BTC 10190A	95	44	30
70 mm stud with 2 layers of 15 mm plasterboard	Studs 70 mm width @ 600 mm centres. Facings Two layers of 15 mm plasterboard both sides (26 Kg/m ²) with staggered joints Insulation 67 mm Acoustic Slab Report No BTC 10183A	132	57	90
70 mm stud with plasterboard fixed to resilient bar	Studs 70 mm width @ 600 mm centres. Facings Two layer 15 mm plasterboard (26 Kg/m ²) sound resisting one side. Other side two layers of 15 mm plasterboard (26 Kg/m ²) fixed to resilient bar. Both sides with staggered joints Insulation 67 mm Acoustic Slab Report No BTC 10187A	143	63	90
146 mm stud with 2 layers of 67 mm Acoustic Slab	Studs 146 mm width @ 600 mm centres. Facings One layer 15 mm Fire rated plasterboard both sides (12 Kg/m ²) Insulation 2 layers of 67 mm Acoustic Slab Report No BTC 10193A	176	53	60

Absorption coefficients

The structure of Rockwool makes it an ideal product for use as a sound absorber.

The absorption coefficients are characteristically high over a wide range of frequencies (see table opposite).

Material	Thickness (mm)	Mounting	Frequency (Hz)					
			125	250	500	1K	2K	4K
Acoustic Slab	47	Direct	0.20	0.50	0.85	1.00	1.00	1.00
Acoustic Slab	67	Direct	0.30	0.70	1.00	1.00	1.00	1.00

Test report numbers BTC 10264A, BTC 10265A



Separating wall utilising existing masonry structure

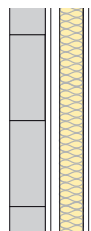

ADE Section 4, wall treatment 1

Minimum D_{nT,w} + C_{tr} 43 dB

- 100 mm (min) existing solid masonry wall plastered on both faces.
- Independent metal stud positioned min. 10 mm from separating wall.
- Rockwool Acoustic Slab 47 mm (min)
- 2 layers of plasterboard (min 20 Kg/m²)

Standards and approvals

Rockwool Acoustic Slab complies with the requirements of BS EN 13162: 2001 Thermal Insulation products for buildings Factory made mineral wool (MW) products specification.

Description

Acoustic Slab is designed specifically to suit installation between metal studs at 600 mm centres. The dimensions of the product have been optimised accordingly.

Dimensions

Standard size: 1200 × 590 mm
Thicknesses: 25, 47 and 67 mm

Performance and properties

Environment

Rockwool insulation products are, and always have been, free from gases that are harmful to the environment, such as CFCs, HCFCs, HFCs, pentane or any gases that have Ozone Depletion Potential (ODP) or Global Warming Potential (GWP).

Fire classification

Acoustic Slab achieves a reaction to fire classification of A1 as defined in BS EN 13501-1.

Work on site

Fixing

Acoustic Slabs are light and easy to cut with a sharp knife.

Metal stud partitions

For installation between metal studs, at 600 mm centres, insert Acoustic Slabs using the standard 590 mm width, and friction fit.

Health and safety

The safety of Rockwool mineral wool is confirmed by current UK and Republic of Ireland health & safety regulations and EU directive 97/69/EC; Rockwool fibres are not classified as a possible human carcinogen.

A Material Safety Data Sheet is available from Rockwool Customer Support (0871 222 1780) to assist in the preparation of risk assessments, as required by the Control of Substances Hazardous to Health Regulations (COSHH).

Sustainability

As an environmentally conscious company, Rockwool promotes the sustainable production and use of insulation and is committed to a continuous process of environmental improvement.

Environment

Relying on entrapped air for its thermal properties, Rockwool insulation does not contain (and has never contained) gases that have Ozone Depleting Potential (ODP) or Global Warming Potential (GWP). Rockwool therefore complies with the relatively modest threshold of GWP<5 included in documents such as the Code for Sustainable Homes.

Rockwool Ltd is increasingly involved in recycling waste Rockwool material that may be generated during installation or at end of life.

We are happy to discuss the individual requirements of contractors and users considering returning Rockwool materials to our factory for recycling.



Maintenance

Once installed Acoustic Slab needs no maintenance and will neither slump nor sag during the lifetime of the partition.

Handling and storage

Rockwool Acoustic Slabs are shrink wrapped in polythene and supplied on pallets that are shrouded with a waterproof hood suitable for outside storage.

Workmanship

To achieve satisfactory sound reduction, it is important to ensure that the separating wall or partition is correctly constructed. Acoustic Slabs must be tightly butted at joints, leaving no gaps.

Typical specification clause

Infill within stud partition

The acoustic infill is to be Rockwool Acoustic Slab, 25/47/67* mm thick, installed to a tight fit between the metal studs.

* Delete as required



SoundPro range of acoustic solutions

Acoustic Slab is a part of the Rockwool SoundPro range of acoustic solutions.

Rockwool Limited reserves the right to alter or amend the specification of products without notice as our policy is one of constant improvement.

The information contained in this data sheet is believed to be correct at the date of publication. Whilst Rockwool will endeavour to keep its publications up to date, readers will appreciate that between publications there may be pertinent changes in the law, or other developments affecting the accuracy of the information contained in this data sheet.

The above applications do not necessarily represent an exhaustive list of applications for Acoustic Slab. Rockwool Limited does not accept responsibility for the consequences of using Acoustic Slab in applications different from those described above. Expert advice should be sought where such different applications are contemplated, or where the extent of any listed application is in doubt.

ROCKWOOL®

Rockwool Limited
Pencoed, Bridgend, CF35 6NY

26-28 Hammersmith Grove
Hammersmith
London
W6 7HA

info@rockwool.co.uk
www.rockwool.co.uk
www.rockwool.ie

Printed on recycled paper

 **More information**
For further details visit our website at www.rockwool.co.uk or phone
Customer Support on 0871 222 1780