

ROCKWOOL®

Fire Barrier Systems

For inhibiting the spread of fire and smoke in concealed spaces

As part of the comprehensive FirePro range of products, Rockwool Fire Barrier systems offer labour-saving solutions to prevent fire and smoke spread within roof and ceiling voids for all general conditions encountered on site. The vertically hung Fire Barriers are capable of achieving both integrity **and** insulation protection periods from 15 to 120 minutes and the friction fitted Fire Barrier Slab can also provide 60 minutes integrity **and** insulation. It is Rockwool's essential insulation performance that limits the heat transfer through the barriers, preventing ignition of combustible materials in adjacent areas.

The new patent applied for, support system (application no. 0329817.1) offers a quick, cost effective installation method for the Fire Barriers for periods up to 60 minutes. This focus on ease of construction and installation has the added benefit of reducing the risks of installation error. 120 minute systems are also available using the traditional support methods. Extended drops are easily catered for, with the system capable of maintaining its performance in void heights up to 10.5 metres.

Fixing solutions to concrete decks – benefits

- fast new patented angle and clamping plate system
- no nuts and bolts to fasten
- simple hammer fix fixing system
- simple angle support with stamped tongues
- one angle supports 2 barriers for 1 hour

Fixing solutions to timber and steel – benefits

- no bolts required
- standard no. 10 wood screws for timber
- self tapping screws for steel purlins
- fixings for clamping plate extended to 450mm
- speed of installation increased
- costs of installation reduced

Firestopping solutions for voids up to 1 metre using Fire Barrier Slab – benefits

- simple butt joint foil faced slab
- no fasteners or angles
- cost of installation reduced
- only 40mm intumescent sealant coat back to penetrations

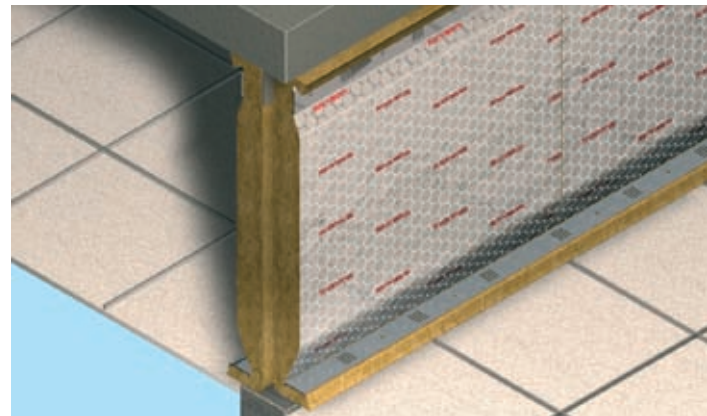

Fixing solutions to concrete decks using Rockwool Fire Barrier

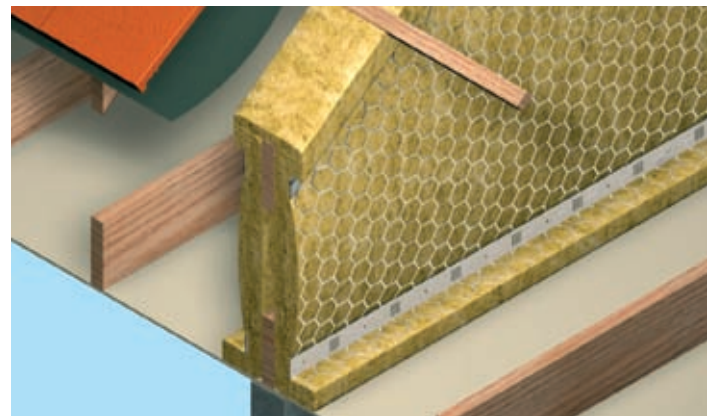

Fixing solutions to timber and steel using Rockwool Fire Barrier

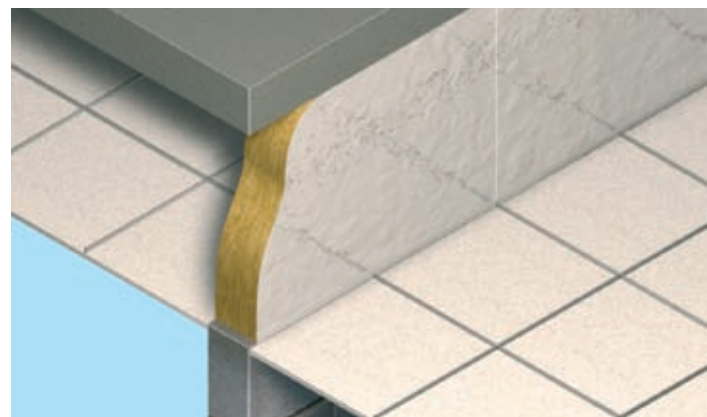

Firestopping solutions for voids up to 1 m using Rockwool Fire Barrier Slab

Description, performance and properties

Contents

	Page No
½ hour Cavity Barrier, ½ hour Fire Barrier	31-32
Common details & penetrations	32
1 hour Fire Barrier	33
1½ and 2 hour Fire Barrier	34
1 hour Fire Barrier Slab	35
Proprietary items and fixings	36
Health & Safety work on site, references	36

Fire Barrier Slab dimensions

1000mm × 600mm × 100mm

Fire Barrier dimensions

Standard width 1 metre

Thickness (mm)	Length (m)
50	4
60	3.5

Fire performance and specification

Product	Fire performance		Specification	
	Integrity (mins)	Insulation (mins)	Report No.	
½ hour Cavity Barrier	60	15	116911	1 layer 50mm
½ hour	60	30	119720	1 layer 60mm Fire Barrier foil faced overlapped joints
1 hour Fire Barrier	60	60	116912	2 layers 50mm Fire Barrier staggered vertical joints
1½ hour Fire Barrier	90	90	51812	2 layers 50mm Fire Barrier staggered vertical joints
2 hour Fire Barrier	120	120	44509	2 layers 60mm Fire Barrier foil faced separated by 40mm airspace
1 hour Fire Barrier Slab	240	60	122729	100mm foil faced slab

It is essential to ensure that the fire insulation criteria of any barrier specified meets the requirements set out in the Approved Document B.

Description

Rockwool Fire Barrier has a 25mm galvanised wire mesh stitched with wire to one face to produce a flexible Fire Barrier with optional aluminium foil faces.

Rockwool Fire Barrier Slab has a factory applied foil finish to both faces.

Rockwool Fire Barrier and Fire Barrier Slab achieve a reaction to fire classification of A1 as defined in BS EN 13501:1

Rockwool Fire Barrier systems have been developed to inhibit the spread of flames, heat and smoke through concealed spaces in buildings and improve sound reduction.

The fixing solutions described in this data sheet have been designed to simplify detailing and incorporate, where possible, commonly available building fasteners and components.

Applications and design

Rockwool Fire Barrier solutions can be applied as a hanging curtain or as a friction fitted slab. The barrier is continuously supported and secured to the soffit at its head. At the base it is preferable in a cavity barrier situation to wire the barrier to the ceiling grid although it is acceptable to let it drape freely, turned back across the ceiling.

If the Fire Barrier is to form a continuation within a void of a fire-resistant wall/partition, it is essential to fix the barrier to the wall/partition head to maintain integrity.

Standards and regulations

Rockwool ½, 1, 1½ and 2 hour cavity/ fire barriers

Satisfies the requirements of the Building Regulations 1991 (2000 edition). Approved Document B and Appendix A, Table A1, for 30 minutes integrity and 15 minutes insulation.

Rockwool Fire Barriers and Fire Barrier Slabs can be used where fire resistant walls need to be continued above a ceiling into the roof void. They conform with the Building Regulations Approved Document B and fulfil all normal fire insulation requirements for divisions of space.

Fire Barrier Systems are third party approved by the Loss Prevention Council Certification board (LPCB) for performance and quality and are listed in the "Red Book" - certificate no. 022c. Certificates can be accessed online at www.rockwool.co.uk or www.redbooklive.com

Useful contacts

The following telephone numbers were correct at the time of going to press:

Hilti: 0800 886 000

Ejot Ecofast Ltd: 01132 470880

Association for Specialist Fire Protection, (ASFP): 01252 357832

Acoustic performance

The correct use of Fire Barrier within structural cavities and voids will reduce the level of transmitted sound.

Room to room attenuation	Rw dB
1 Typical lay-in grid suspended ceiling	30
2 As above, with 50mm Rockwool Fire Barrier	42
3 Applied as 2, but Rockwool Fire Barrier foil faced	44
4 Applied as 2, but two thickness of 50mm Rockwool Fire Barrier – both foil faced	50
5 Rockwool Fire Barrier Slab foil faced both faces	50
6 If ceiling is plasterboard, add between 2-3 db	

Note: values are approximate

SoundPro range of acoustic solutions

Fire Barrier Systems are part of the Rockwool SoundPro range of acoustic solutions. Further information on the SoundPro range is available from Rockwool Marketing Services on 01656 862621.



Rockwool patented angle support

½ hour Cavity Barrier – Typical fixing methods

Figures 1–6 show typical details for Fire Barrier applied to a timber truss construction as a half hour cavity barrier within the roof space to satisfy the requirements of Building Regulation B3 – (4).

If the truss is constructed from a minimum timber size of 35 to 49mm thick, both sides of all truss members/bracing require protection from fire in order to minimise charring. Figure 3 shows strips of 50mm Fire Barrier used on the reverse side of the truss for this purpose.

Alternatively, a second layer of Fire Barrier may be applied to provide 1 hour fire rating (see Fig 17).

Nail plate fixings may fail prematurely in fire unless protected (see Fig 6).

The new Rockwool fixing system incorporates an angle support and clamping plate.

For fixing to timber, the Rockwool clamping plate is used, compressing the barrier to the timber, fixed at 450mm centres using No. 10 woodscrews.

For fixing to concrete soffits, the pre-punched angle support is fixed using Hilti DBZ or Ejot ECL 35 hammer set anchors at max. 750mm centres.

For fixing to steel purlins, use Hilti SMD o2Z (5.5 × 70mm) self-tapping screws at max. 450mm centres.

To use the patented Rockwool angle support system, bend tongues out to 90° and impale barrier onto them. The slotted clamping plate is then fitted by pushing the tongues through the slots and these are then bent over the face of the clamping plate completing the process.

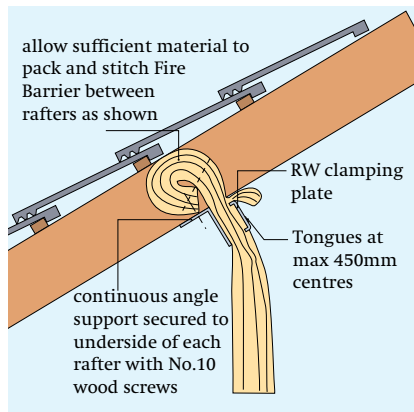
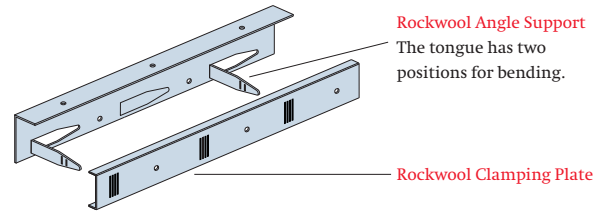

Figure 1 Fire Barrier transverse to rafters

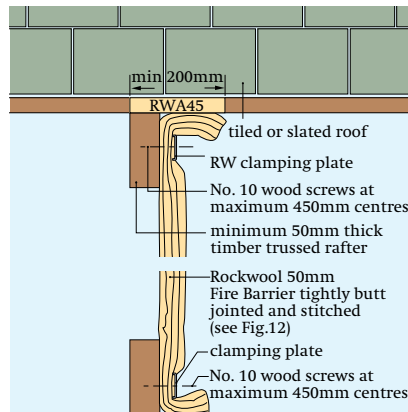

Figure 2 Half hour protection for timber truss construction 50mm thick or more. Note: Nail plate protection required – see Figure 6

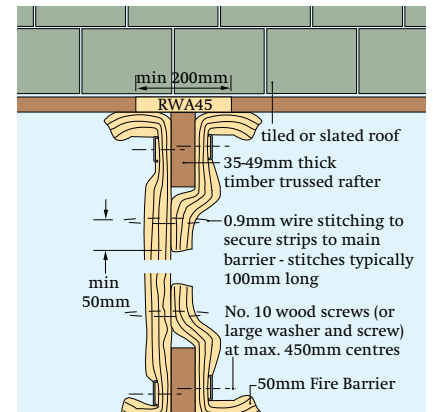

Figure 3 Half hour protection for timber truss construction 35 to 49mm thick

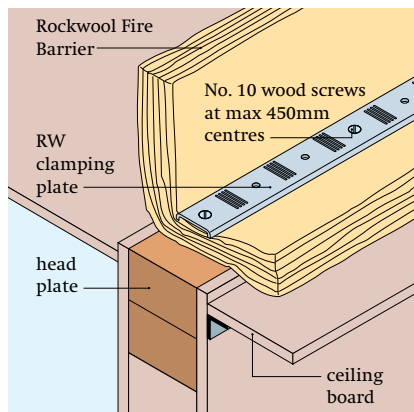

Figure 4 Head of partition

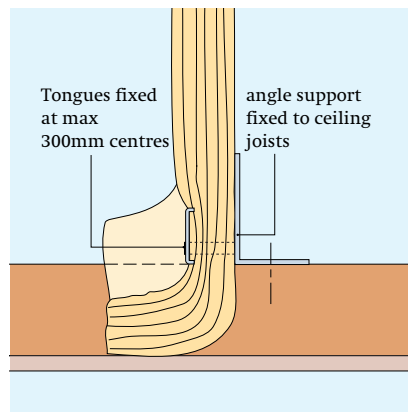

Figure 5 Barrier fitted transversely to timber joisted ceiling

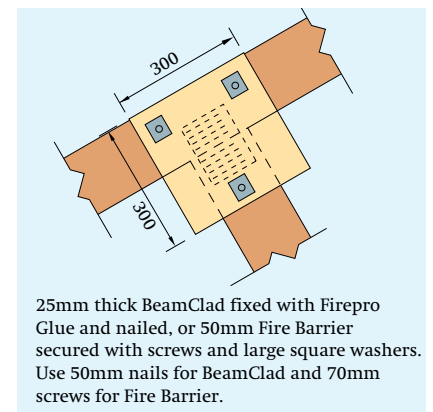

Figure 6 Nail plate protection

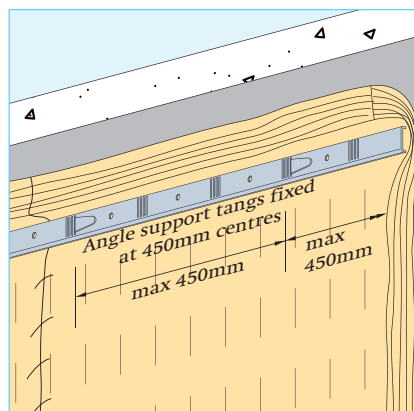

Figure 7 50mm Fire Barrier fixed to concrete soffit

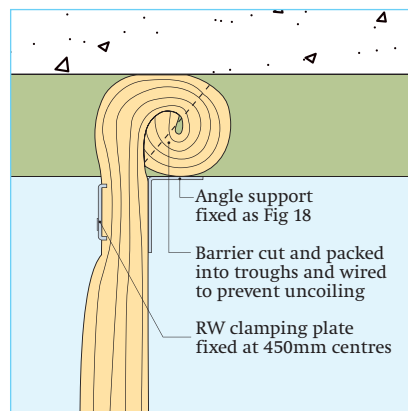

Figure 8 50mm Fire Barrier running across ribbed soffit - Section

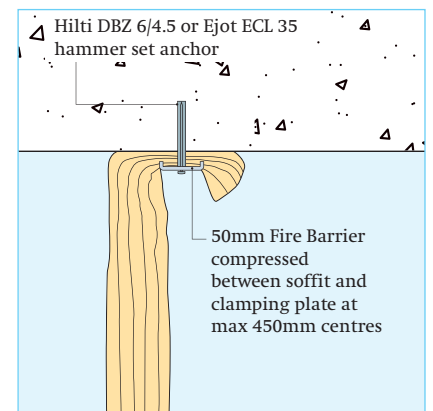

Figure 9 Alternative fixing to flat soffit or perimeter, appropriate to barriers with a shallow drop

½ hour Cavity Barrier – Typical fixing methods continued

60-30 Fire Barrier

If 30 minutes insulation is required, use 1 layer of 60mm foil faced fire barrier with 100mm vertical overlapped joints (Fig 13). The barrier is otherwise fixed as previously shown for timber construction on page 31.

Common details

Extended drops

Rockwool 50mm Fire Barrier single and double layers can be extended from a 3.5m drop to a maximum 6m drop by fixing an additional 2.5m section stitched with overlapped joints as per Figure 14. For drops over 6m in length please refer to Figure 30 (back page).

Wire stitching of butt joints in Rockwool Fire Barriers

Adjacent barriers must be closely butt jointed, or overlapped, and through stitched with 0.9mm galvanised annealed wire. It is essential that the barrier provides a good seal at its head, perimeter and at all joints. Where the barrier abuts a profile such as a trapezoidal deck, the material must be cut to suit and secured to fire stop the gap (see Fig.10). For extended drops 1.5mm width galvanised, annealed wire is used.

Penetration details

It is regarded as good practice to adequately support or reinforce – services penetrating compartment walls and cavity barriers to prevent displacement. It is recommended that such supports should be no greater than 500mm from each face of the Fire Barrier.

To maintain the integrity of the Fire/Cavity Barrier when penetrated by services with a high melting point such as steel or copper pipes, beams

or trusses etc., the barrier is first cut locally to accommodate the service or structural member and then re-stitched as neatly as possible. The penetration is then lightly sleeved each side of the barrier to a minimum length of 300mm, using the same barrier material. Each sleeve should be securely stitched to the main barrier to produce a tight seal and prevent future detachment (see figures 14 and 16). Where access is only available from one side, the double seal solution may be replaced by a single ‘collar’ detail – please contact Rockwool for further advice.

If the penetrating service is manufactured from low melting point materials such as plastic or aluminium, then sleeving should be extended to at least 1000mm either side of the barrier. This guidance applies to services such as pipes, sheathed cables and conduits, including those carried on steel trays.

For protected steel ductwork with a tested fire resistance performance (stability, integrity and insulation) at least the same as the Fire Barrier, 300mm sleeves should be applied either side of the main barrier, as for high melting point services above. For information on achieving fire protection to steel ductwork, please refer to the Rockwool Fire Duct System data sheet. For non-fire protected ductwork, or that with a fire resistance performance less than the barrier, two sleeves should be applied to each side of the barrier. An inner sleeve of 1000mm and an outer sleeve of 300mm. All sleeves should be stitched to the main barrier. The duct should also include an independently supported fire damper, located in the line of the main barrier.

Reference should also be made to Approved Document B of England & Wales Building Regulations – Volume 1, Requirement B3, Section 7 and Volume 2, Requirements B3, Section 10.

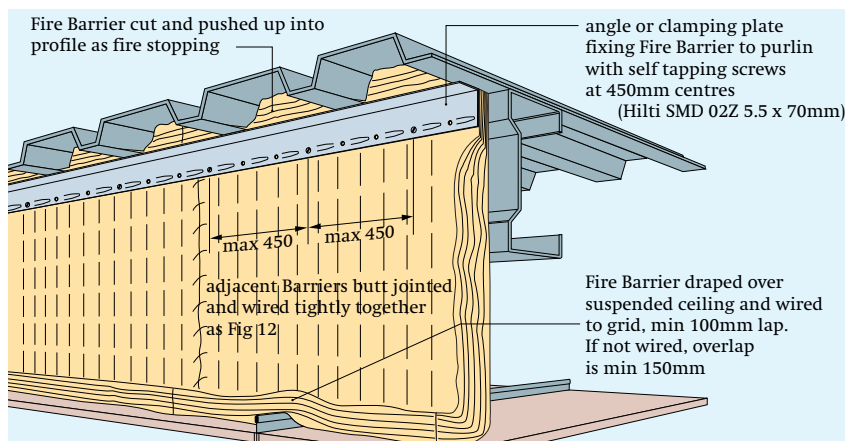

Figure 10 50mm Fire Barrier applied below metal roof decking

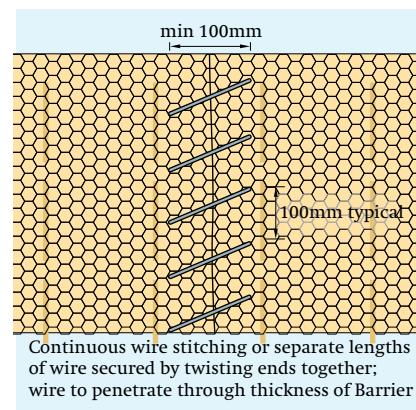

Figure 11 Joint in Barrier – Elevation

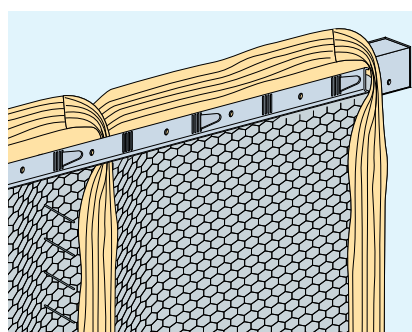

Figure 12 60mm Fire Barrier with overlap joints to obtain 60 mins integrity 30 mins insulation

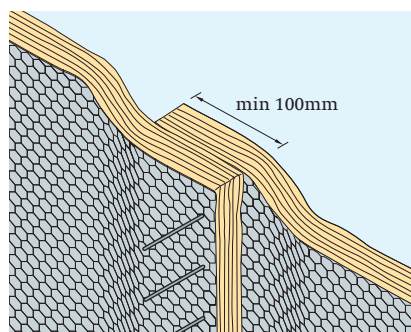

Figure 13

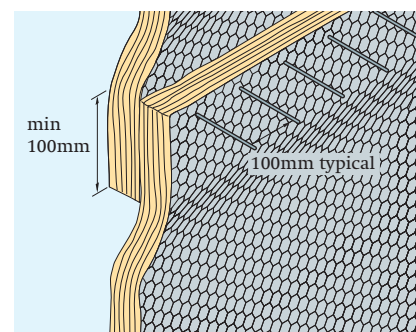

Figure 14 50mm Fire Barrier extended from 3.5m to 6m using a 1.5mm dia. wire-stitched overlapped joint

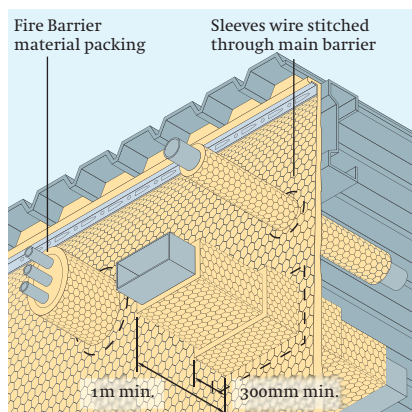

Figure 15 Penetration of Fire Barrier by pipework and ductwork. Length of pipe sleeving: 300mm for high melting point pipes such as steel or copper, 1,000mm for lower melting point pipes such as plastic or aluminium.

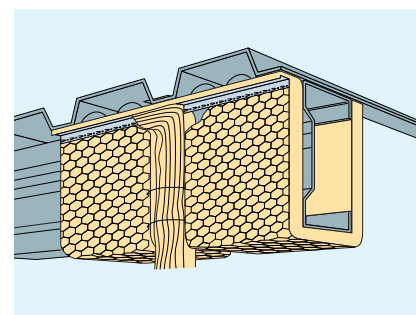

Figure 16 50mm Fire Barrier running parallel with metal deck profiles
NB. Fire barrier must be fixed to a structural loadbearing support between purlings

1 hour Fire Barrier – Typical fixing methods

The unique, patented Rockwool support angle and clamping plate is used to fasten two 50mm Fire Barrier curtains with one support angle without the need for an airspace.

The Rockwool support angle has tongues that are pushed out from opposite sides at 300mm max. centres. The Rockwool Fire Barriers are then impaled on the tongues on both sides and clamped using the Rockwool clamping plates. The tongues are finally bent over the clamping plates, completing the system.

The system uses 50mm Fire Barrier in a double layer with joints staggered.

Note that wire reinforced sides should be placed outwards.

Fixing to timber structure (1 hour)

When a 1 hour Fire Barrier is supported on structural timber (for example a trussed rafter), and the thickness of timber is 35-49mm, one layer of 60mm Rockwool Fire Barrier must be placed on each side of the timber (see Figure 18).

Where timber thickness is 50mm or greater, 2 layers of 50mm Fire Barrier are sufficient.

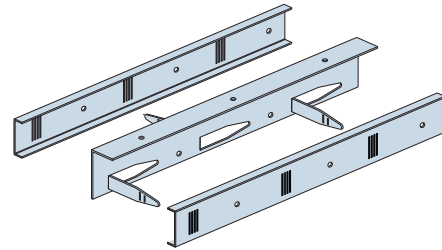

Rockwool Angle Support and Clamping Plate arrangement for one hour applications

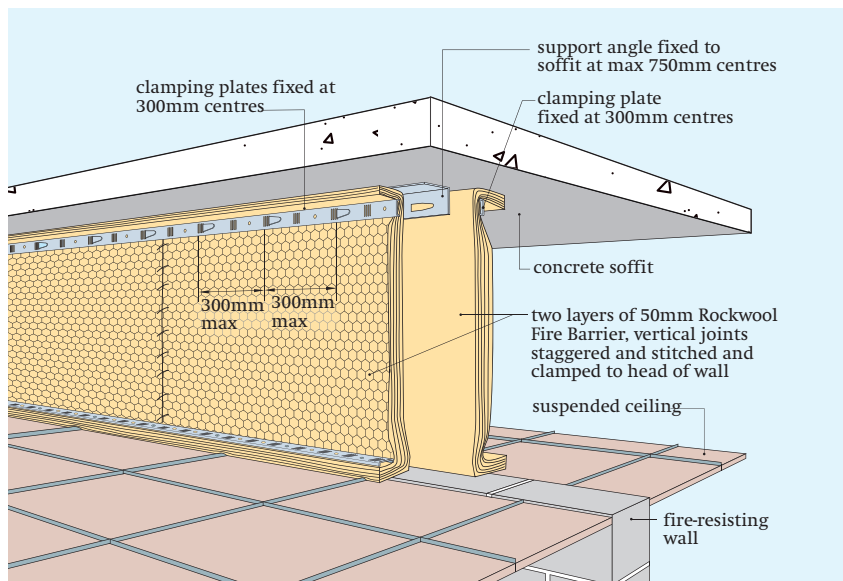

Figure 17 One hour Fire Barrier – General view

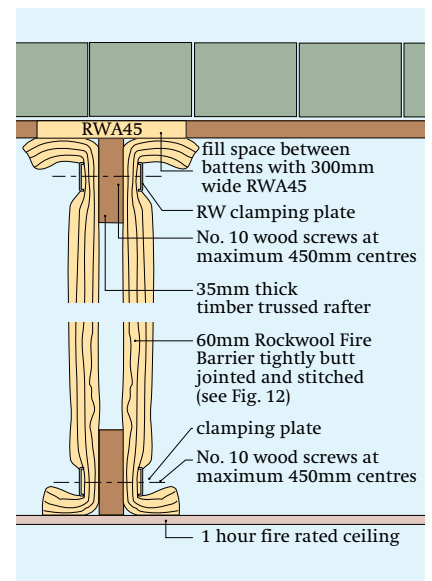

Figure 18 One hour protection for timber truss construction between 35 - 49mm thick

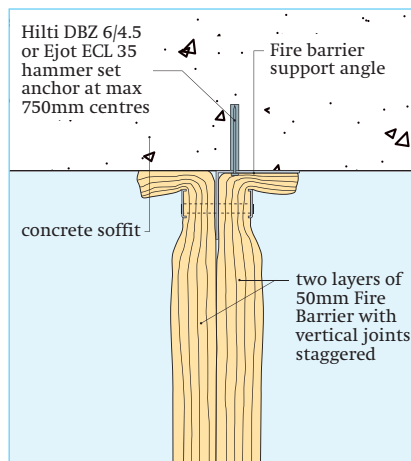

Figure 19 One hour – fixing to head

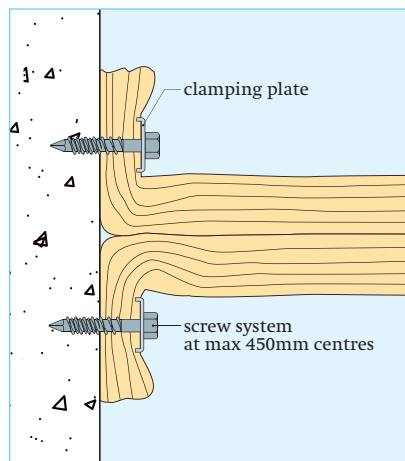

Figure 20 One hour Fire Barrier Perimeter fixing – Plan view

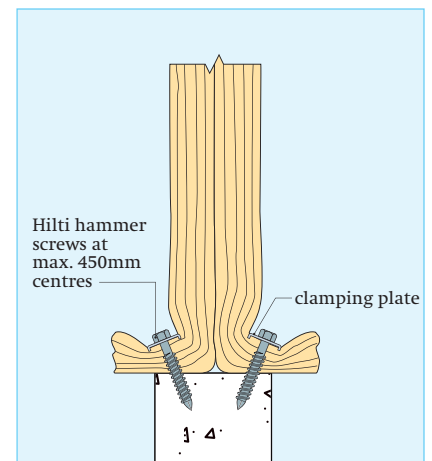

Figure 21 One hour – Fire Barrier Base detail

1½ hour and 2 hour Fire Barrier – typical fixing methods

Concrete roof and soffit constructions

1½ hour Fire Barrier

The Rockwool 1½ hour Fire Barrier system uses 2 layers of 50mm fire barrier with staggered joints fixed as Fig. 22-24.

Note that the wire reinforced faces should be placed outwards.

2 hour Fire Barrier

The Rockwool 2 hour Fire Barrier consists of two layers of 60mm foil-faced, wire stitched Fire Barrier with staggered vertical joints, separated by a nominal 40mm air space.

The base or perimeter to which the barrier is fixed must be capable of remaining in place for 2 hours.

Angle and strap for 1½ and 2 hour firebarriers

The following specification for slotted angles and straps has been found, by test, to be suitable for supporting Rockwool Fire Barriers for 1½ and 2 hours when tested to BS 476: Part 22.

Slotted angles (62 × 41 × 2mm) and straps (38 × 2mm) manufactured from mild steel conforming to BS 1449: Part 1.1: 1991 and cold reduced to provide a minimum of 0.2% proof stress of 417 Mpa (27 tons/in²) and conforming to BS 4345: 1968 (1986) – Specification for slotted angles (inc. flat strap).

Durability

For durability we recommend that the finish should be capable of withstanding at least 200 hours salt spray and 400 hours humidity corrosion resistance testing to BS 3990: Part F.

Slotted angles and straps conforming to this specification are available from the following suppliers:

JB Products	Tel: 01384 240234
Link 51	Tel: 01952 682251
Romstor	Tel: 01442 242261

If other hardware is used to support the barriers, we would strongly recommend that the respective specifier, supplier or installer satisfy themselves totally, via reference to the fixing manufacturer, that the chosen fixing system has been tested and approved for the required period of fire resistance and drop height.

Site advisory service

Rockwool Ltd provides a site advisory service by engineers solely employed to assist with advice when installing Rockwool materials on site. The service is intended for site guidance, but is not intended to be an inspection facility unless agreed under a separately financed contract agreement.

For approval of installed barriers, the installer or building owner will be referred to a suitably accredited and experienced fire assessor or fire safety engineering organisation.

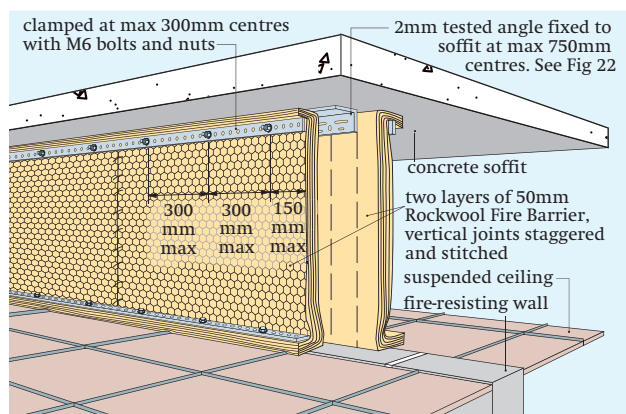

Figure 22

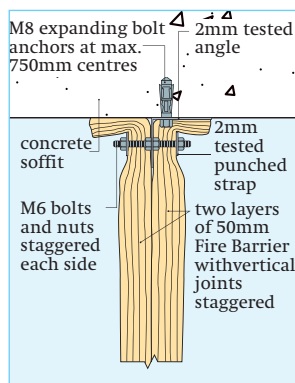

Figure 23 1½ hour Fire Barrier – Section at head

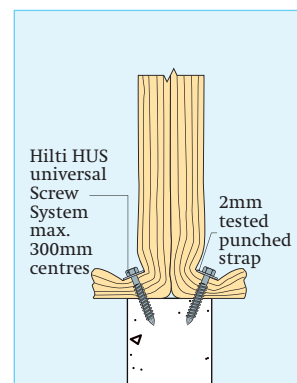

Figure 24 1½ hour Fire Barrier – Section at base

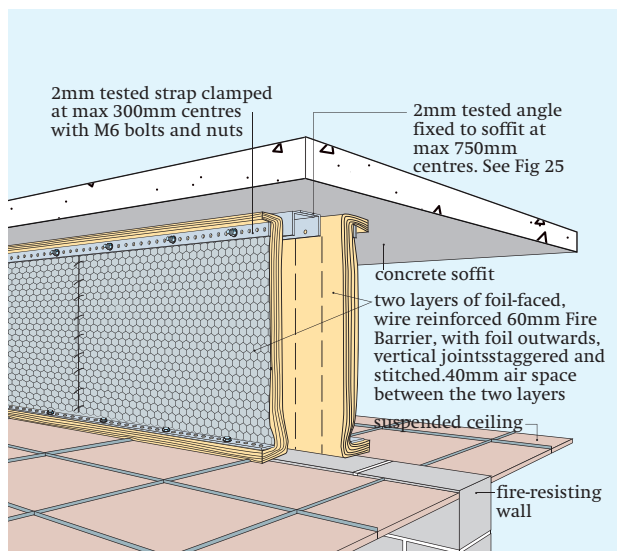

Figure 25 Two hour Fire Barrier – General view

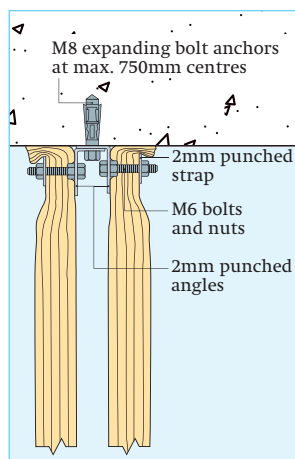

Figure 26 Two hour Fire Barrier – Section at head

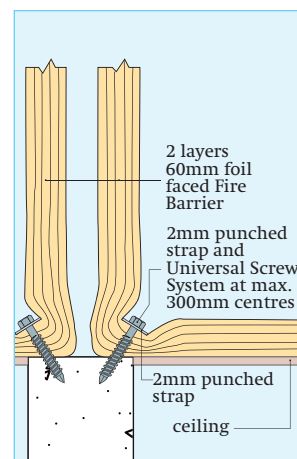

Figure 27 Two hour Fire Barrier – Base detail

Fire Barrier Slab

Fire Barrier Slab offers a new solution to this typical application for up to 4 hours integrity. Rockwool Fire Barrier Slab is an aluminium foil faced slab used to close voids up to 1m in height and 20m in length supported by a masonry wall (minimum density of 400 kg/m³) offering the same fire performance.

The slabs are cut to height and friction fitted within the opening. Acoustic Intumescent Sealant is applied to the butt joints and perimeter of the barrier.

Service penetrations

The Rockwool Fire Barrier Slab can be penetrated by steel pipes of up to 33mm external diameter or smaller, and steel cable trays of 305 × 50mm or smaller.

These penetrating services must be independently supported a maximum of 150mm from the face of the slabs. Acoustic Intumescent Sealant is applied to form a tight bond where the penetration passes through the face of the slab, as shown in Figure 29.

Fire performance of Rockwool Fire Barrier Slab

No penetrations 4 hour integrity; 1 hour insulation

Service penetrations 1½ hour integrity; 1 hour insulation

When subjected to BS 476:Part 20 and 22: 1987 – reference WFRC – report C122729.

Rockwool Acoustic Intumescent Sealant

All joints use Acoustic Intumescent Sealant to ensure a tight fit during a fire situation.

Flammability

When subjected to flame, Acoustic Intumescent Sealant will intumesce (expand and char), thus blocking the passage of smoke and flame, see Figure 29.

Service temperature range

-20°C to +70°C

Coverage

Based on a 9mm × 6mm joint, one tube will cover approx. 5.5 linear metres. Acoustic Intumescent Sealant must be applied with a minimum width of 6mm and a max width of 20mm.

The Acoustic Intumescent Sealant will allow for 10% compression and tension movement with a butt joint.

Acoustic Intumescent Sealant is supplied in 310 ml tubes, 25 tubes to a box.

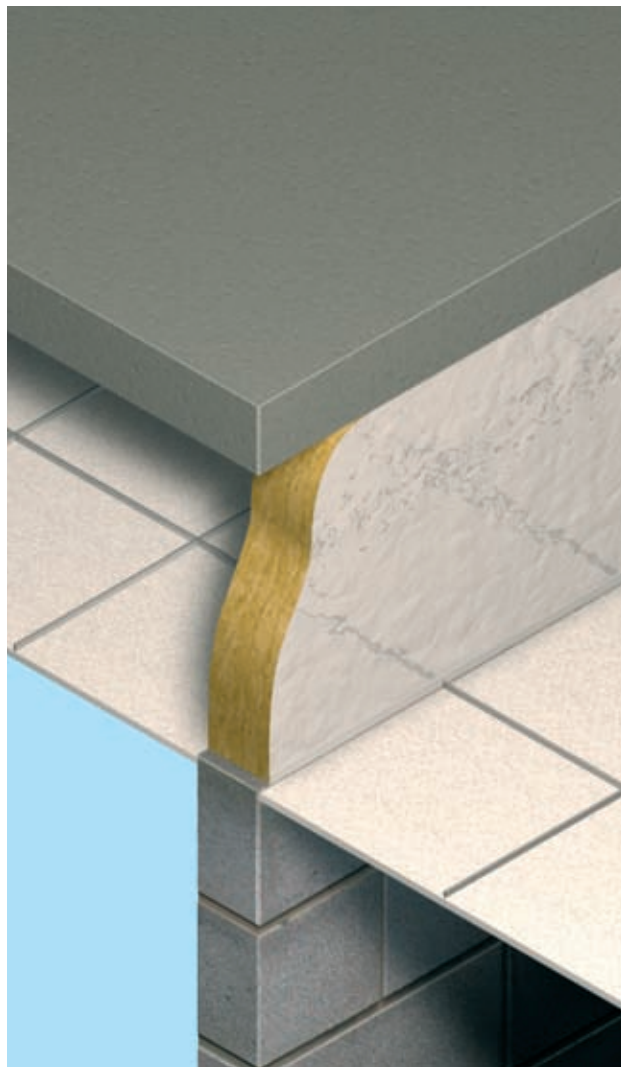

Figure 28 One hour Fire Barrier Slab – general view

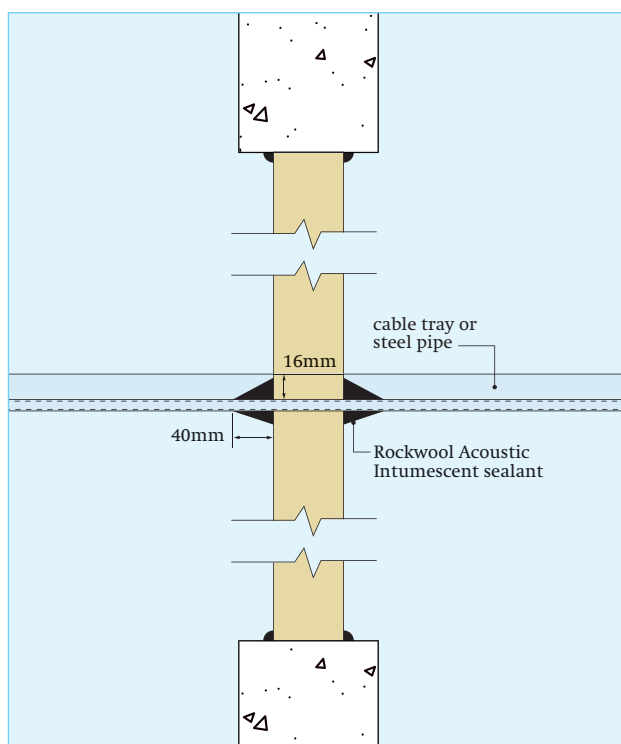

Figure 29 Section through steel penetration

Proprietary fixings

All steel hammer set expansion anchors for soffit fixings are available from Hilti, or Ejot. For perimeter fixings to concrete or masonry, use: Hilti HUS Universal Screw system. For fixings to timber, use standard No. 10 steel wood screws 100mm long.

References

Publications

For further information on the design of cavity barriers and firestops, reference should be made to the BRE Current Paper 7/77 whilst BRE Digest Nos. 214 and 215 discuss practical problems and solutions.

Supply

Rockwool Fire Barrier support angle and clamping plate are specially manufactured for Rockwool.

Clamping Plate:

3metres × 40mm, 10 lengths per pack

Fire Barrier Support Angles:

3m × 34mm × 75mm, 10 lengths per pack

Rockwool Acoustic Intumescent Sealant:

310ml cartridges, 25 per box

Prices and conditions of sale

Available on request from Rockwool Limited.

Packaging of Fire Barrier

Shrink wrapped in polyethylene.

Packaging of Fire Barrier Slabs

Two slabs per pack enclosed in polythene.

General design considerations

A cavity fire barrier must be designed to restrict the passage of both hot smoke and flame for the minimum specified period, as listed in Approved Document B in support of the Building Regulations. In addition, it must be fixed in such a way that: (a) it will remain effective in the event of structural movement; (b) there are no gaps where it abuts other elements of construction, and (c) it complies with the requirements of Approved Document B of the Building Regulations.

Extended drops

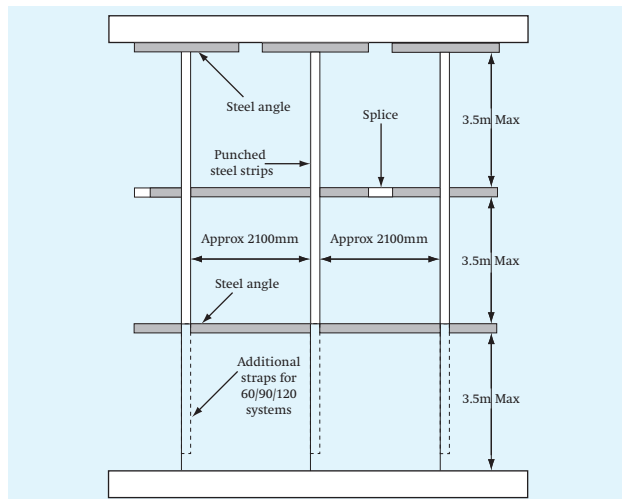

Figure 30

Rockwool Fire Barriers, for periods up to 60 minutes, can be used for extended void heights between 3.5 and 6m without the need for a supported frame – see Figure 14 for joining barriers with overlap. For periods of up to 90 minutes this drop height can be increased to 10.5m (9m for 120 minutes), by the use of a simple frame system constructed from slotted angles and straps (see 1½ and 2 hour support systems). Further details are available from Technical Services.

Barrier Configuration	Maximum Height (with no additional support)	Maximum Height (with additional support)	Integrity	Insulation
50mm single layer	3 metres 6 metres*	10.5 metres	60 minutes 30 minutes	15 minutes 15 minutes
50mm double layer	3.5 metres 6 metres*	10.5 metres	90 minutes 60 minutes	90 minutes 60 minutes
60mm double layer (with cavity between layers)	3.5 metres	9 metres	120 minutes	120 minutes

*Horizontal overlapped joint required (see fig.14)

Fire barriers and dampers

Where Rockwool Fire Barriers are installed in conjunction with fire dampers, the dampers must be supported independently of the fire barrier. HVCA or ASFP publications may be helpful.

Access through Barriers

Where regular access is required through the barriers for maintenance purposes etc., this should be achieved by the inclusion of an independently supported fire rated door set and frame. The Fire Barriers should be clamped to the door frame with the RW clamping plate and appropriate fixings at 450mm centres.

Work on site

Handling and storage

Rockwool Fire Barriers are easy to handle. It is easy to cut to any shape. The product should be stored indoors or under a weatherproof covering.

Maintenance

Once installed Rockwool Fire Barriers should need no maintenance.

Health and safety

Current HSE 'CHIP' Regulations and EU directive 97/69/EC confirm the safety of Rockwool mineral wool; Rockwool fibres are not classified as a possible human carcinogen. The maximum exposure limit for mineral wool is 5mg/m³, 8 hour time-weighted average.

A Material Safety Data Sheet is available from Rockwool Customer Support (0871 222 1780) to assist in the preparation of risk assessments, as required by the Control of Substances Hazardous to Health Regulations (COSHH).

Environment

Relying on entrapped air for its thermal properties, Rockwool insulation does not contain (and has never contained) gases that have Ozone Depleting Potential (ODP) or Global Warming Potential (GWP). Rockwool therefore complies with the relatively modest threshold of GWPL₅ included in documents such as the Code for Sustainable Homes.

Rockwool Ltd is increasingly involved in recycling waste Rockwool material that may be generated during installation or at the end of life

disposal. We are happy to discuss the individual requirements of contractors and users considering returning Rockwool materials to our factory for recycling.



More information

For further details visit our website at www.rockwool.co.uk or phone Customer Support 0871 222 1780

ROCKWOOL®

Rockwool Limited Pencoed, Bridgend, CF35 6NY
info@rockwool.co.uk www.rockwool.co.uk

Printed on recycled paper using environmentally friendly processes

Rockwool Limited reserves the right to alter or amend the specification of products without notice as our policy is one of constant improvement.

The information contained in this data sheet is believed to be correct at the date of publication. Whilst Rockwool will endeavour to keep its publications up to date, readers will appreciate that between publications there may be pertinent changes in the law, or other developments affecting the accuracy of the information contained in this data sheet.

The above applications do not necessarily represent an exhaustive list of applications for Fire Barrier. Rockwool Limited does not accept responsibility for the consequences of using Fire Barrier in applications different from those described above. Expert advice should be sought where such different applications are contemplated, or where the extent of any listed application is in doubt.